

HAVANA WHITE 82-60

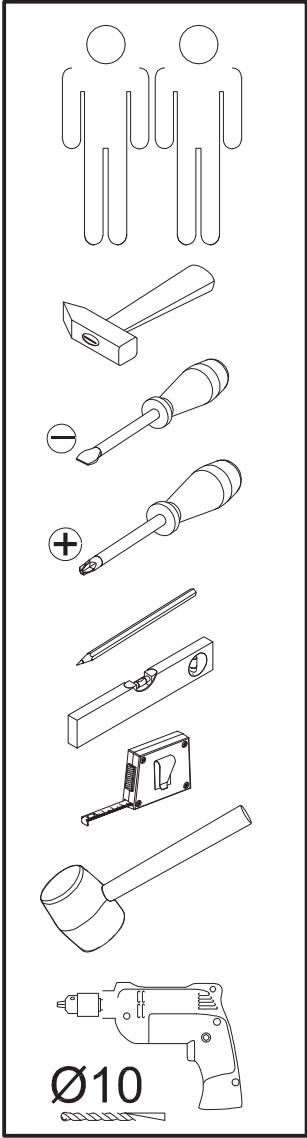

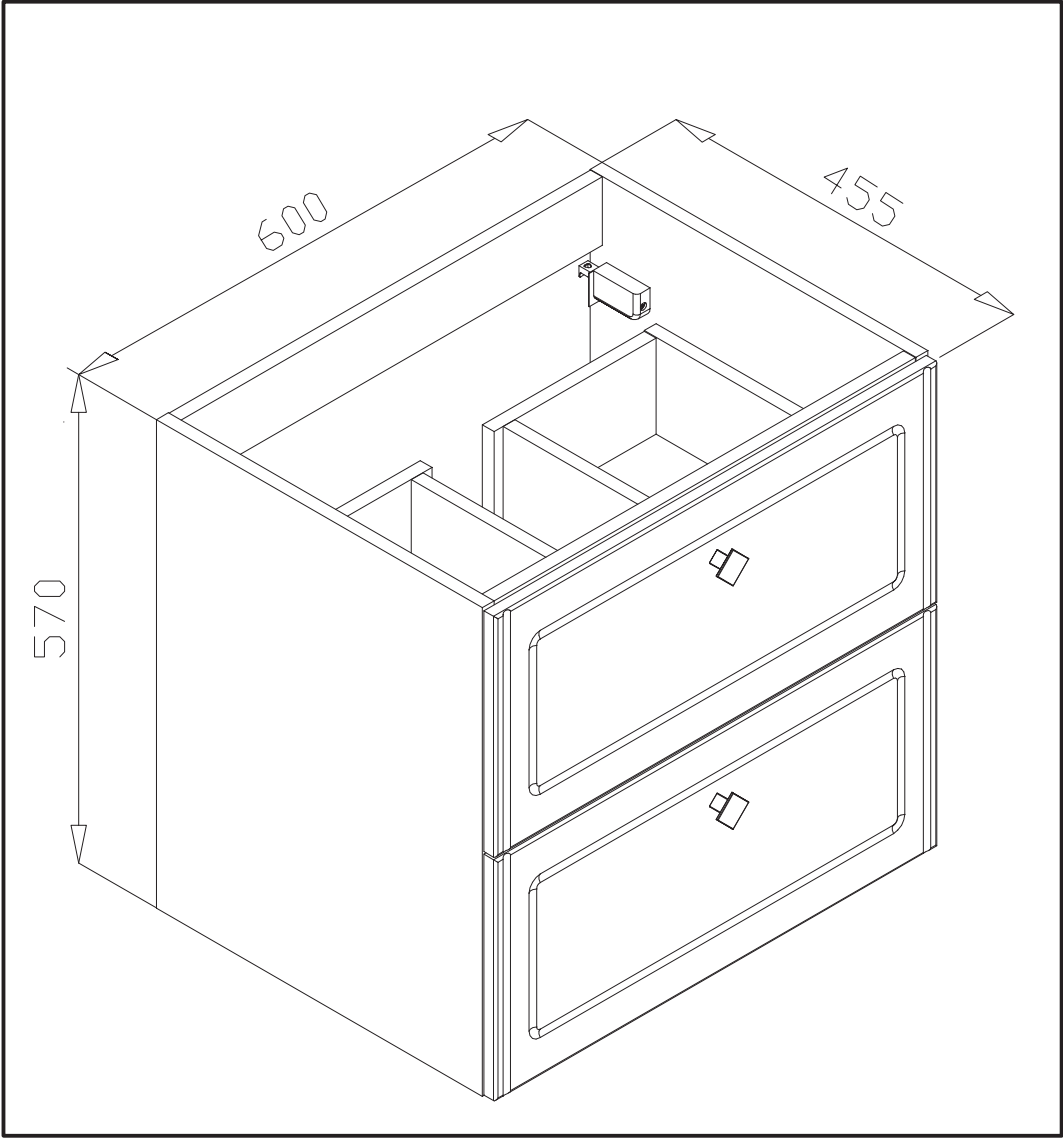
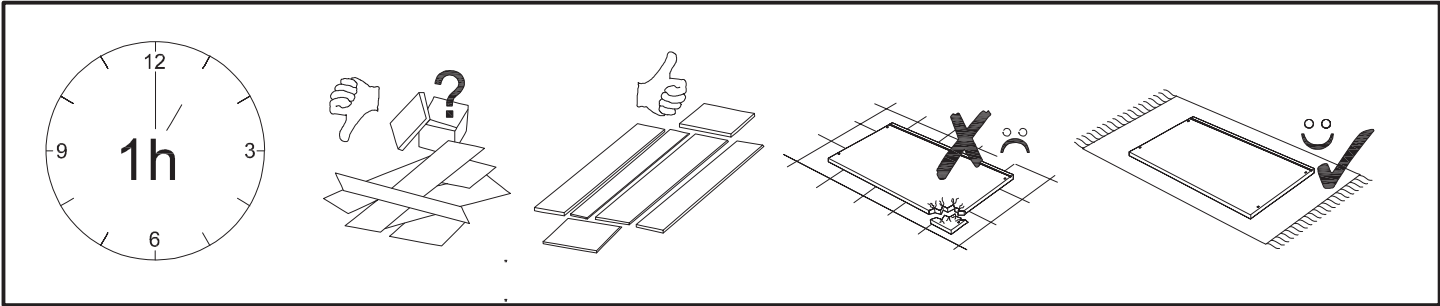
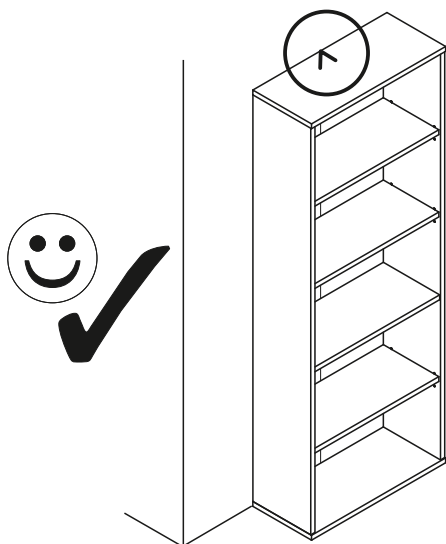

PL.
 UWAGA! Mebel należy trwale zamocować do ściany, aby uniknąć ryzyka związanego z przewróceniem się mebla. W paczce znajdują się elementy mocujące odpowiednie wyłącznie do ścian betonowych lub z pełnej cegły. Jeśli Twoja ściana wykonana jest z innego materiału lub nie masz pewności co do budowy tej ściany, skonsultuj się w kwestii montażu ze specjalistą.

RU.
 ПРИМЕЧАНИЕ! Эту мебель необходимо всегда прикреплять к стене, чтобы избежать рисков, связанных с переворотом мебели. В пакете находятся крепежные элементы, которые подходят исключительно к бетонным стенам или из целого кирпича. Если стена изготовлена из другого материала или Вы не уверены относительно строения стены, проконсультируйтесь относительно монтажа со специалистом.

I.
 ATTENZIONE! Il mobile deve essere permanentemente fissato alla parete per evitare i rischi derivanti da un ribaltamento del mobile. La confezione contiene solo elementi di fissaggio adatti per pareti in calcestruzzo o in laterizio pieno. Se la vostra parete è realizzata in materiale diverso o avete dubbi sulla costruzione della parete, consultare uno specialista per un montaggio corretto.

SLO.
 POZOR! Pohištvo trajno pritrdite na steno, da preprečite tveganje, da se prevrne. V paketu so pritriljni elementi, ki so ustrezni izključno za betonske stene in za stene iz polne opeke. Če je vaša stena izdelana iz drugih materialov ali niste gotovi glede konstrukcije stene, se o montaži posvetujte s strokovnjakom.



EN.
 WARNING! To prevent this furniture from tripping over, fix it to the wall permanently. The package includes fastening elements only suitable for concrete or full-brick walls. If your wall is made of a different material or you are unsure as to the construction of the wall, please consult a specialist regarding installation.

FR.
 ATTENTION! Ce meuble doit être fixé en permanence au mur pour éviter les risques de chute. L'ensemble comprend des moyens de fixation adaptés uniquement aux murs de béton ou de brique. Si votre mur est fait d'un matériau différent ou si vous êtes incertain quant à la construction du mur, consultez un spécialiste.

HR.
 NAPOMENA! Namještaj mora biti trajno pričvršćen za zid, kako bi se izbjegao rizik od njegova prevrtanja. U paketu se nalaze elementi za pričvršćivanje prikladni isključivo za betonske zidove ili punu ciglu. Ako je Vaš zid izrađen od drugog materijala ili niste sigurni od čega je napravljen Vaš zid, konzultirajte se sa stručnjakom u vezi sa montažom.

CZ.
 POZOR! Nábytek je nutné pevně připevnit ke zdi, abychom se vyhnuli riziku spojenému s jeho převrnutím. V balíčku se nacházejí připevňující prvky vhodné výhradně do betonových zdí nebo zdí z plných cihel. Pokud jsou Vaše zdi zhotoveny z jiného materiálu nebo si nejste jejich konstrukcí jisti, konzultujte otázku montáže se specialistou.

CN.
 注意！本家具需要固定在墙上以免倒塌。
 本包所含有的固定部件仅适用于混凝土墙及整砖墙。
 欲使用在其他墙体或不确定墙体时，
 请向专家询问安装方式。

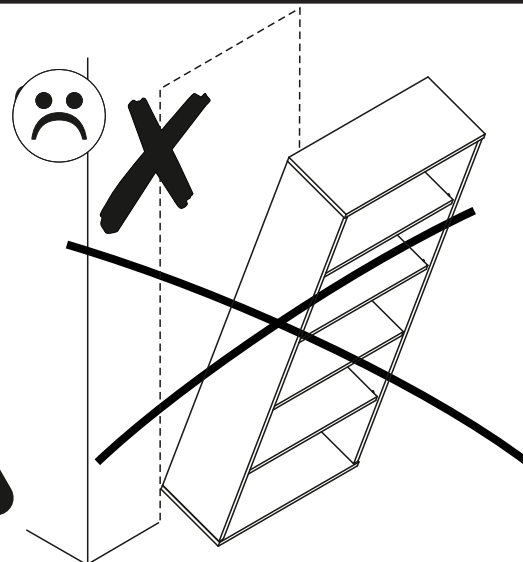

D.
 ACHTUNG! Um alle mit dem Umkippen des Möbels verbundenen Risiken auszuschließen, muss das Möbel fest an der Wand verankert werden. Die im Paket enthaltenen Beschläge für die Wandbefestigung sind ausschließlich für Wände aus Beton oder Vollziegeln geeignet. Sollten die heimischen Wände aus anderem Baumaterial bestehen oder sollte es Zweifel in Hinsicht auf dieses Baumaterial geben, bitte eine Fachkraft zu Rate ziehen.

HU.
 FIGYELEM! Rögzítse a bútorokat a falhoz, hogy elkerülje a bútor felborulásának kockázatát. A készletben kizárólag beton- vagy téglafalhoz használható kötőelemek találhatók. Ha a fal más anyagból készült, vagy ha nem tudja, milyen falak találhatók otthonában, forduljon szakemberhez.



SK.
 POZOR! Nábytok musí byť trvalo pripevnený k stene tak, aby sa zamedzilo riziku prevrátenia. V balíku sa nachádzajú upevňovacie komponenty výlučne pre betónové steny alebo steny z plnej tehly. Ak je Vaša stena z iného materiálu alebo ak si nie ste istí, z čoho je stena vyhotovená, vyžiadajte si odbornú pomoc.

E.
 ¡ATENCIÓN! El mueble debe ser fijado permanentemente a la pared para evitar el riesgo relacionado con el vuelco del mueble. En el paquete hay elementos de fijación adecuados solo para paredes de hormigón o de ladrillo entero. Si su pared está hecha de otro material o no está seguro sobre la construcción de esta pared, consulte el montaje con un especialista.

HAVANA WHITE 82-60

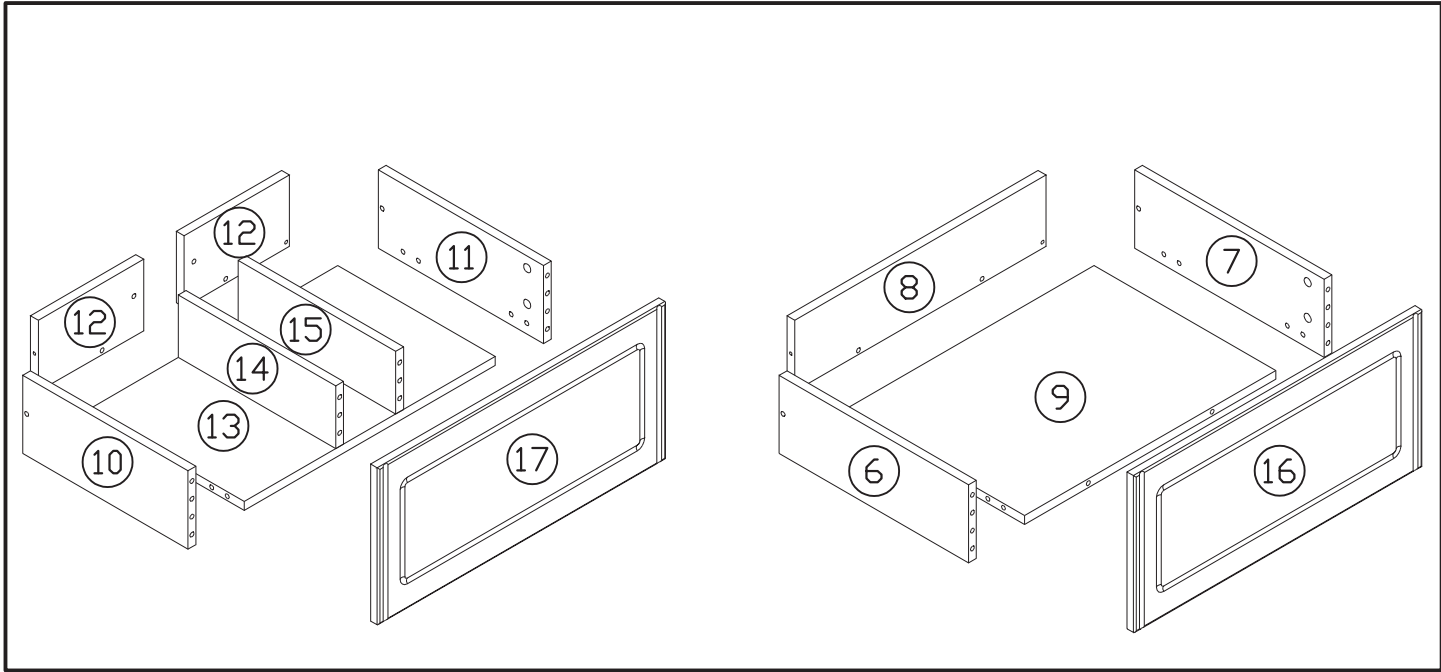
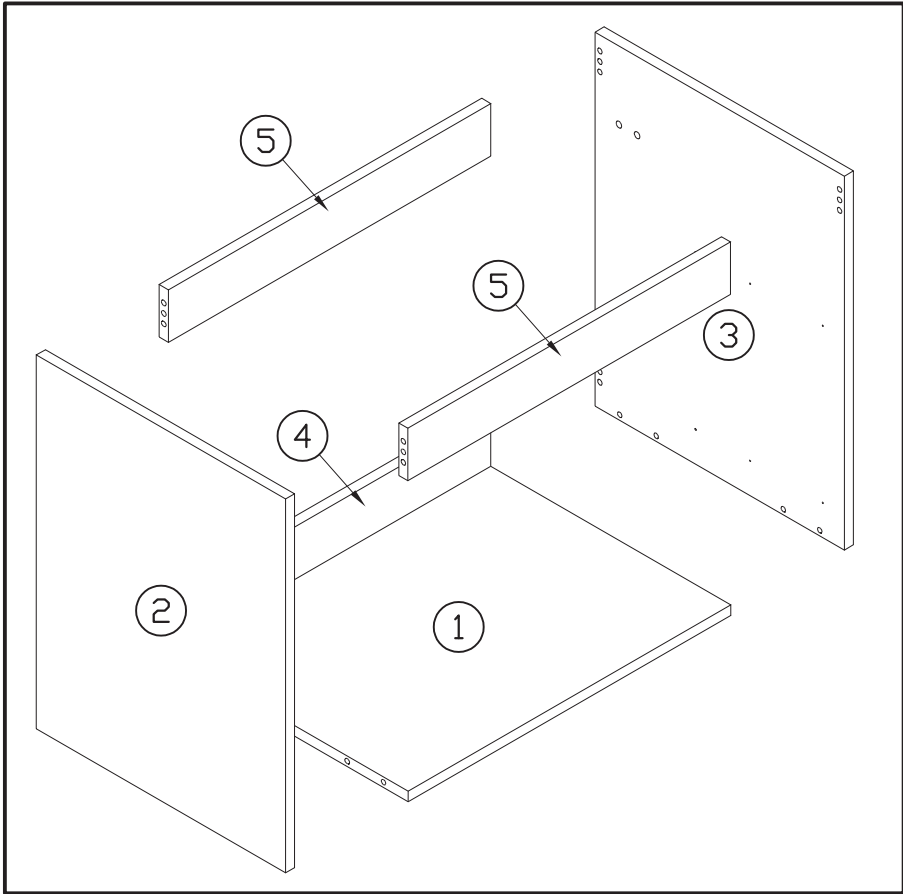
#	L	B	S	Q
1	439	568	16	1
2	570	439	16	1
3	570	439	16	1
4	80	568	16	1
5	80	568	16	2
6	140	392	16	1
7	140	392	16	1
8	128	520	16	1
9	376	520	16	1
10	140	342	16	1
11	140	342	16	1
12	128	218	16	2
13	326	520	16	1
14	112	326	16	2
15	112	326	16	2
16	596	281	16	1
17	596	281	16	1

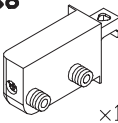
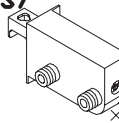
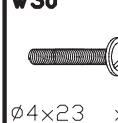
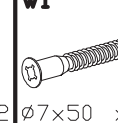
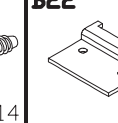
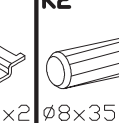
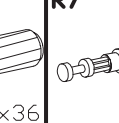
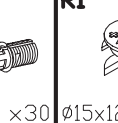
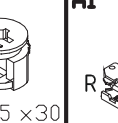
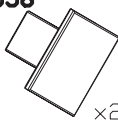
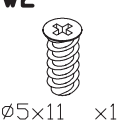

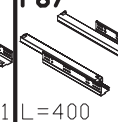
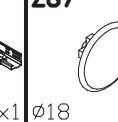
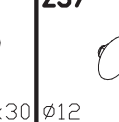
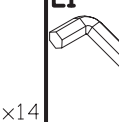
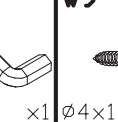
S8  x1	S7  x1	W30  ø4x23 x2	W1  ø7x50 x14	B22  x2	K2  ø8x35 x36	R7  x30	R1  ø15x12,5 x30	A1  x2
U58  x2	W2  ø5x11 x12	P86  L=350 x1	P87  L=400 x1	Z67  ø18 x30	Z57  ø12 x14	L1  x1	W9  ø4x16 x12	

HAVANA WHITE 82-60

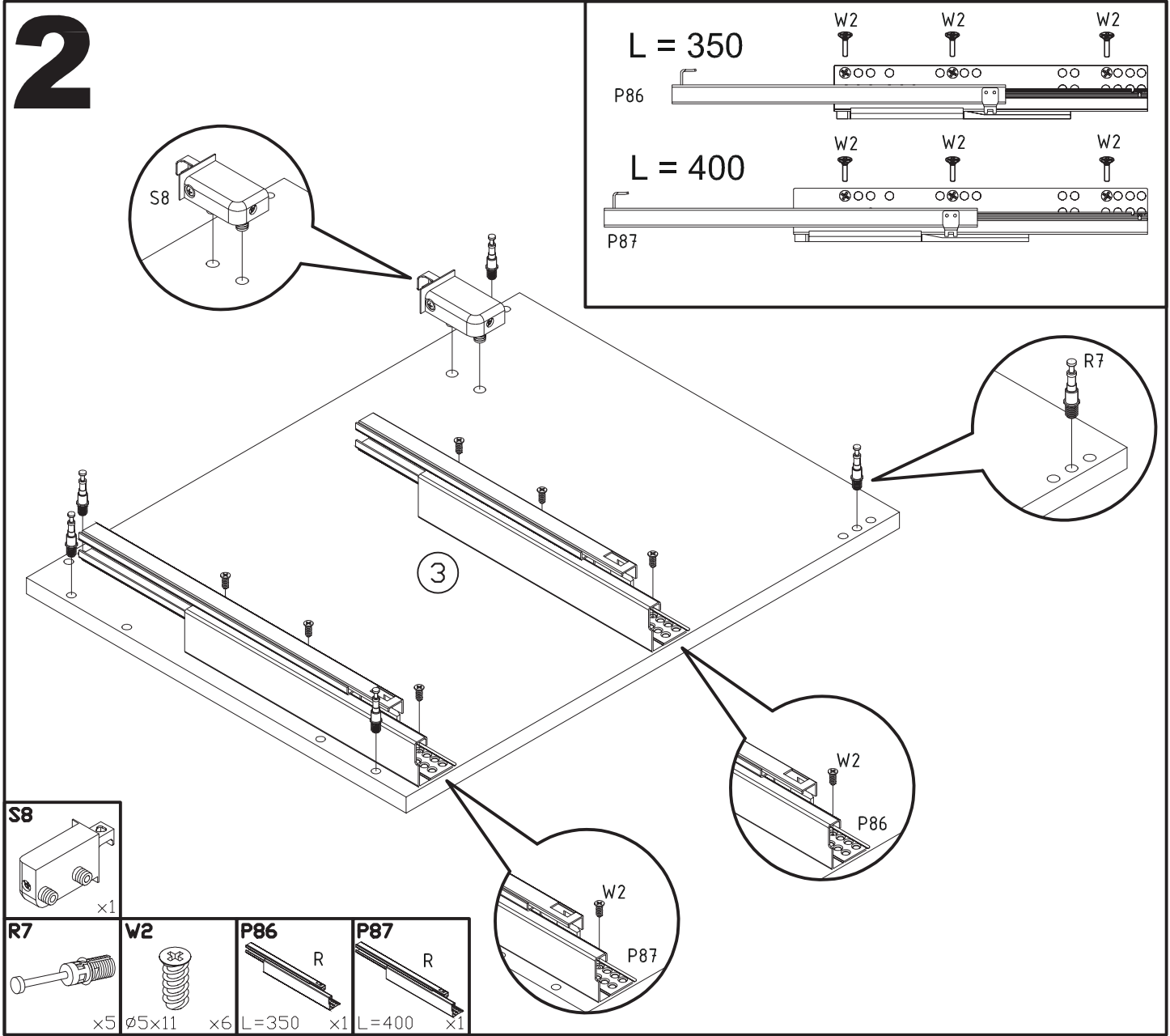
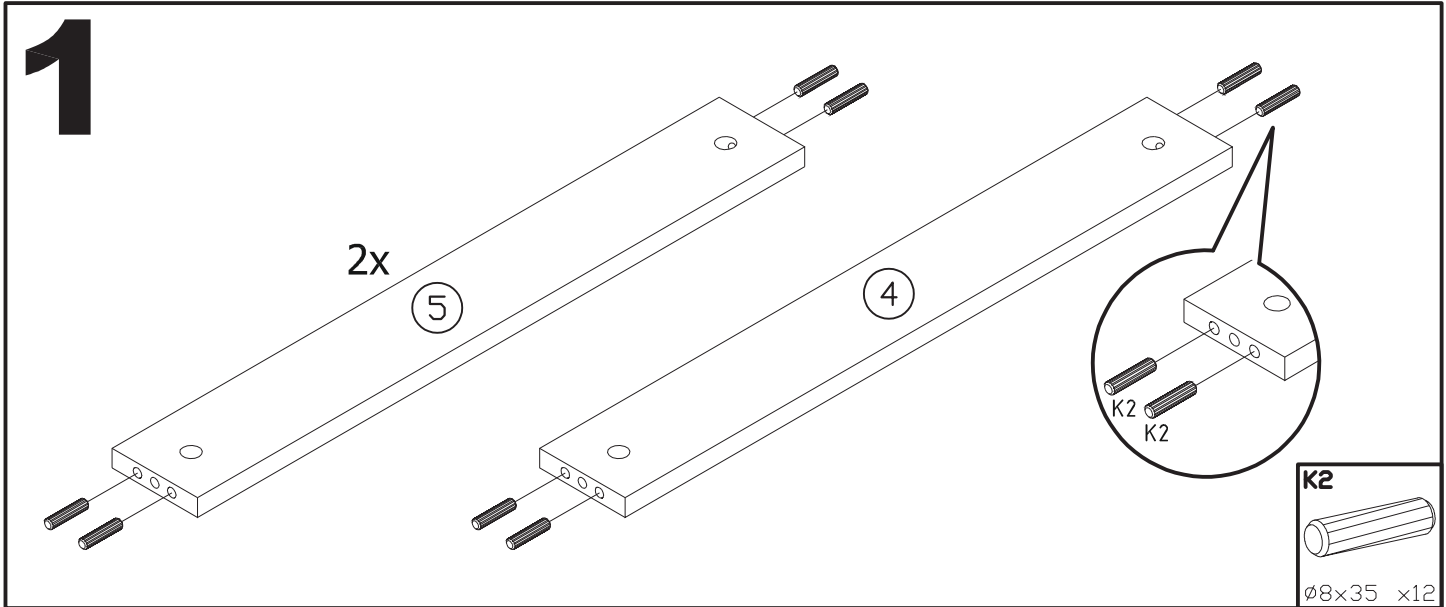
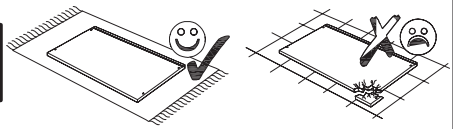

HAVANA WHITE 82-60

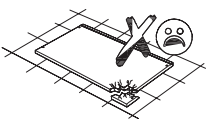
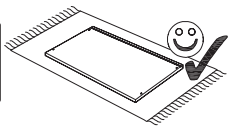

3

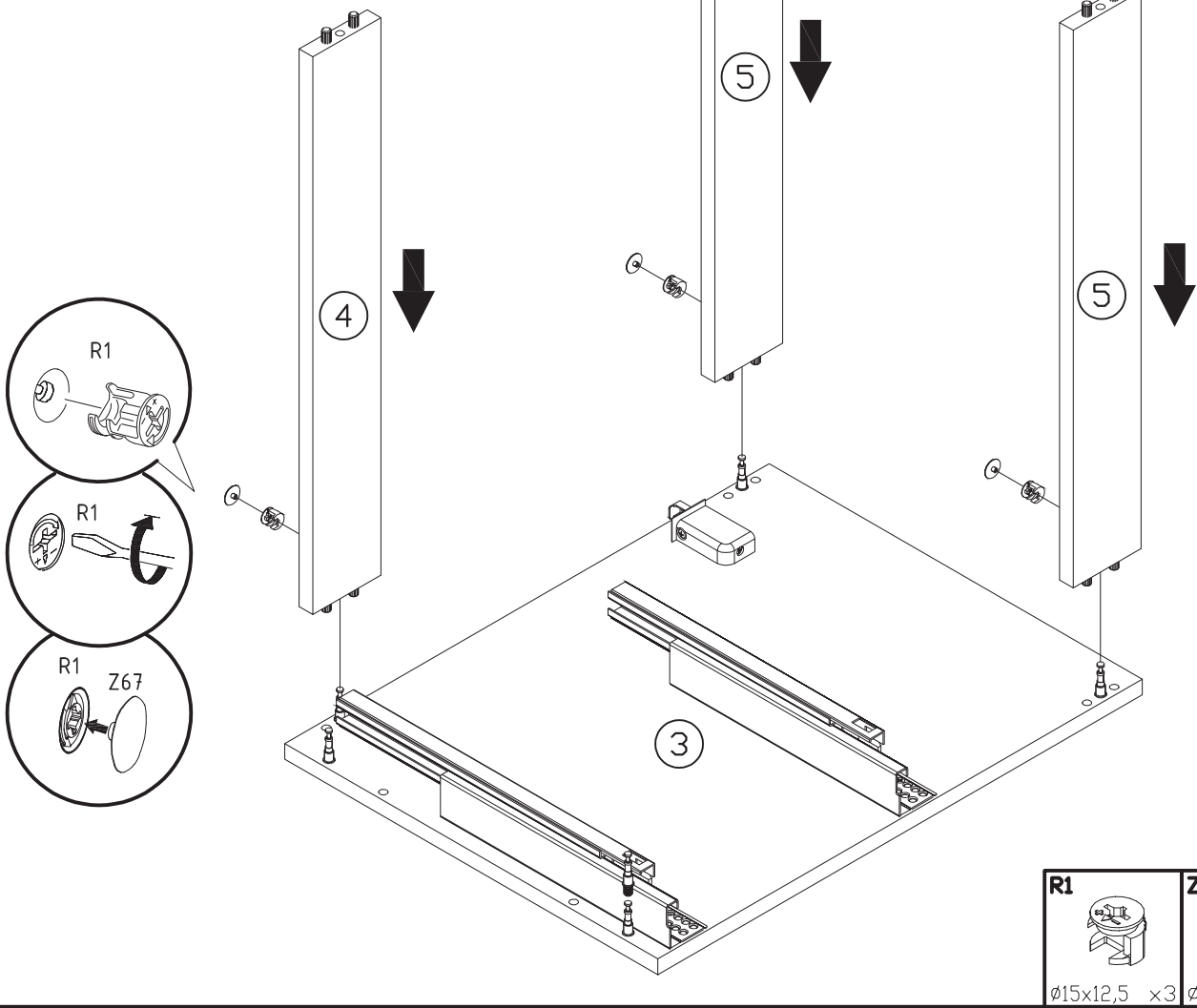

4

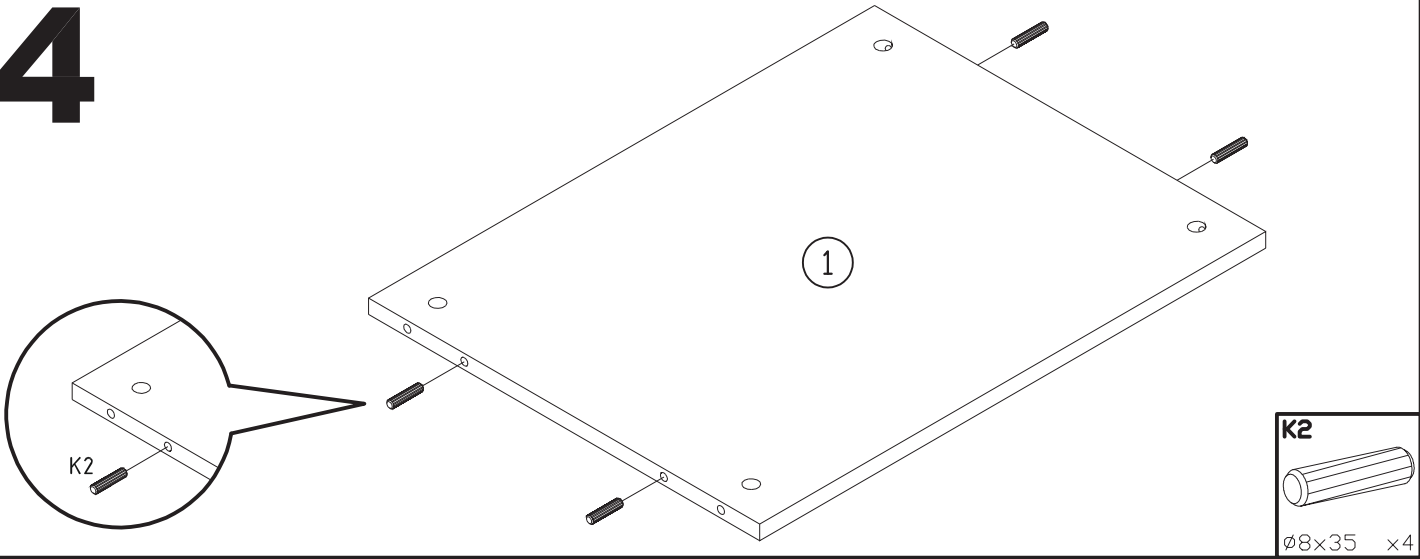

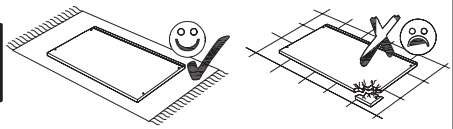

HAVANA WHITE 82-60



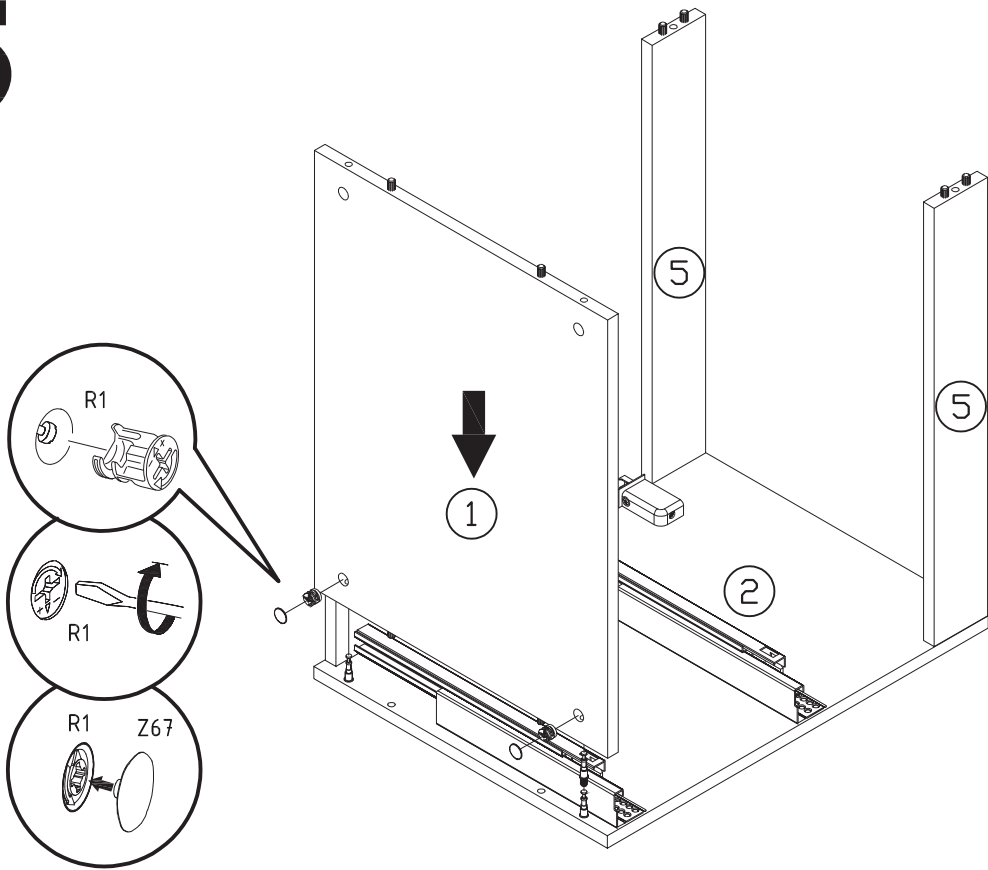

5

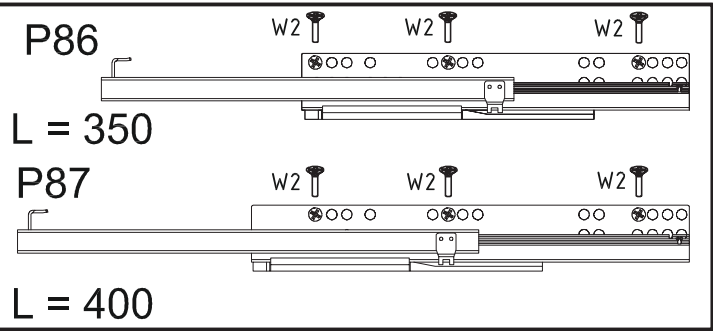
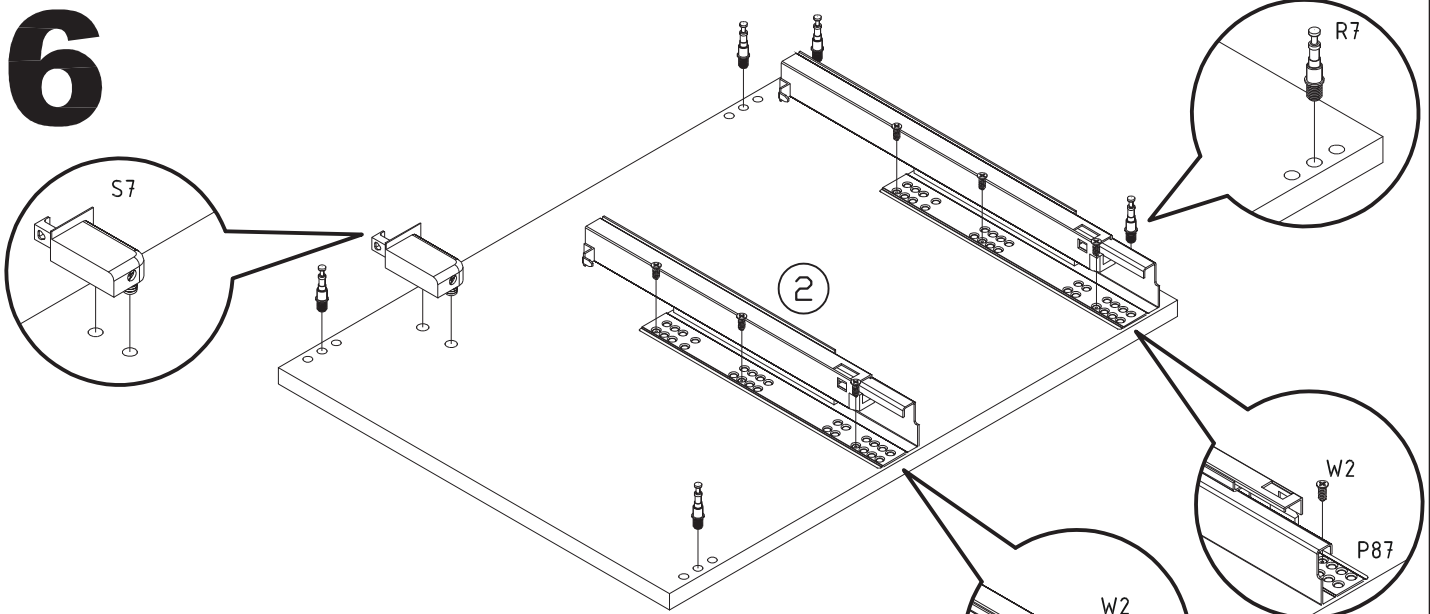

R1  Ø15x12,5 x2	Z67  Ø18 x2
--	--

6

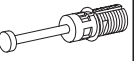
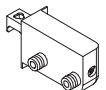

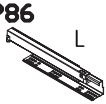
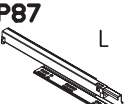

R7  x5			
S7  x1	W2  Ø5x11 x6	P86 L  L=350 x1	P87 L  L=400 x1

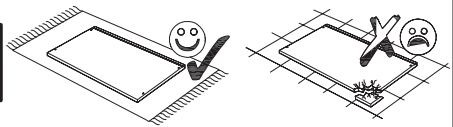
HAVANA WHITE 82-60

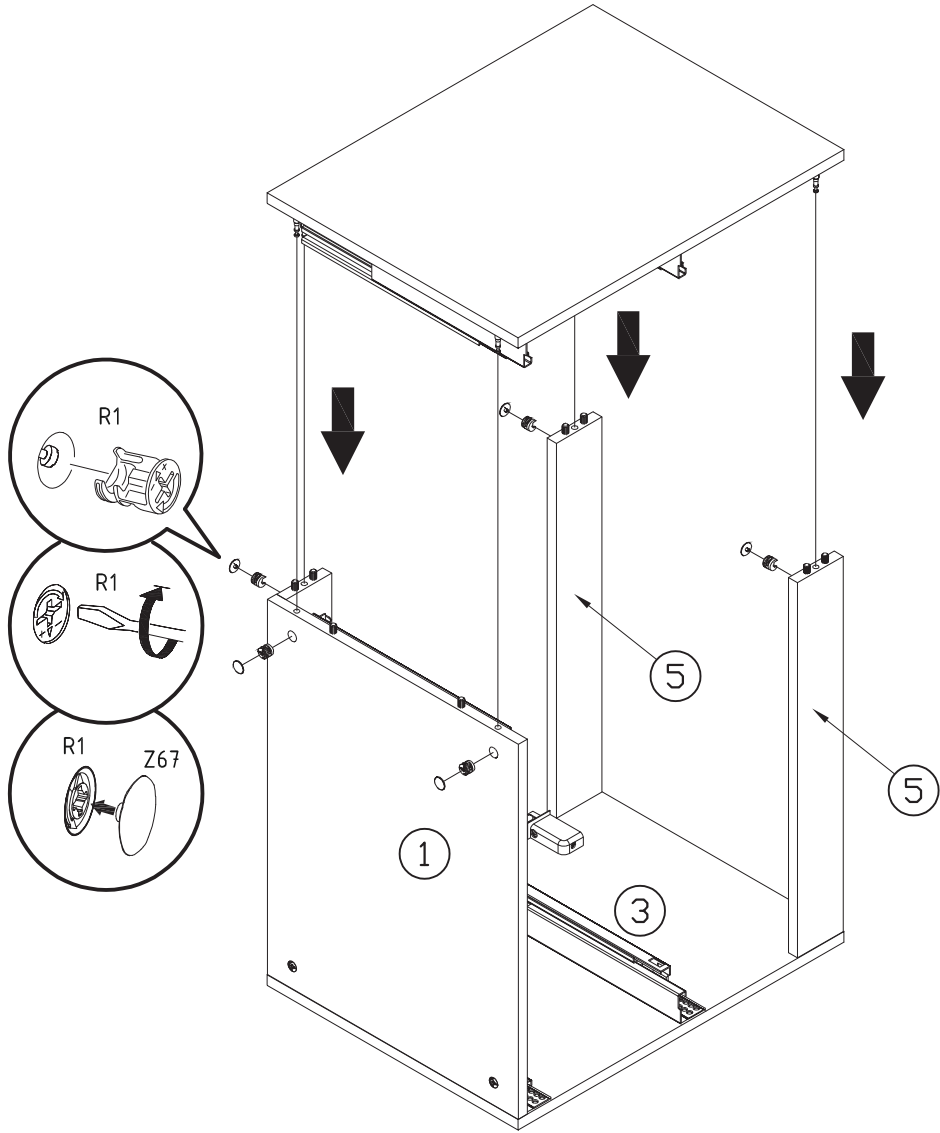

7



R1  Ø15x12,5 x5	Z67  Ø18 x5
---	---

8

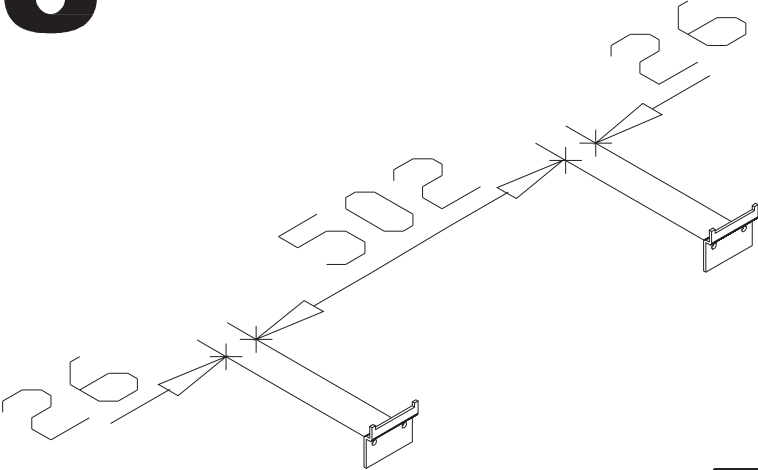

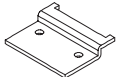
B22  x2

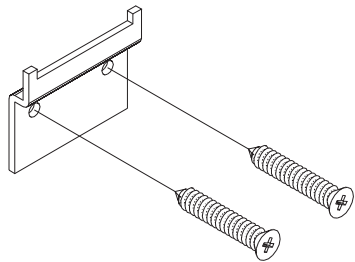
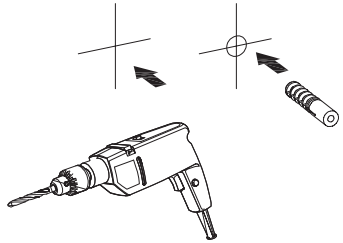
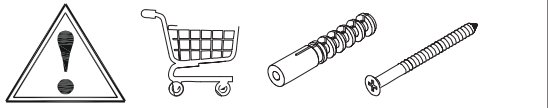

HAVANA WHITE 82-60

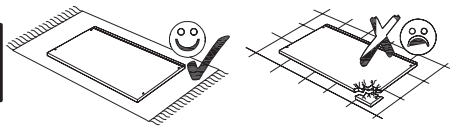

9

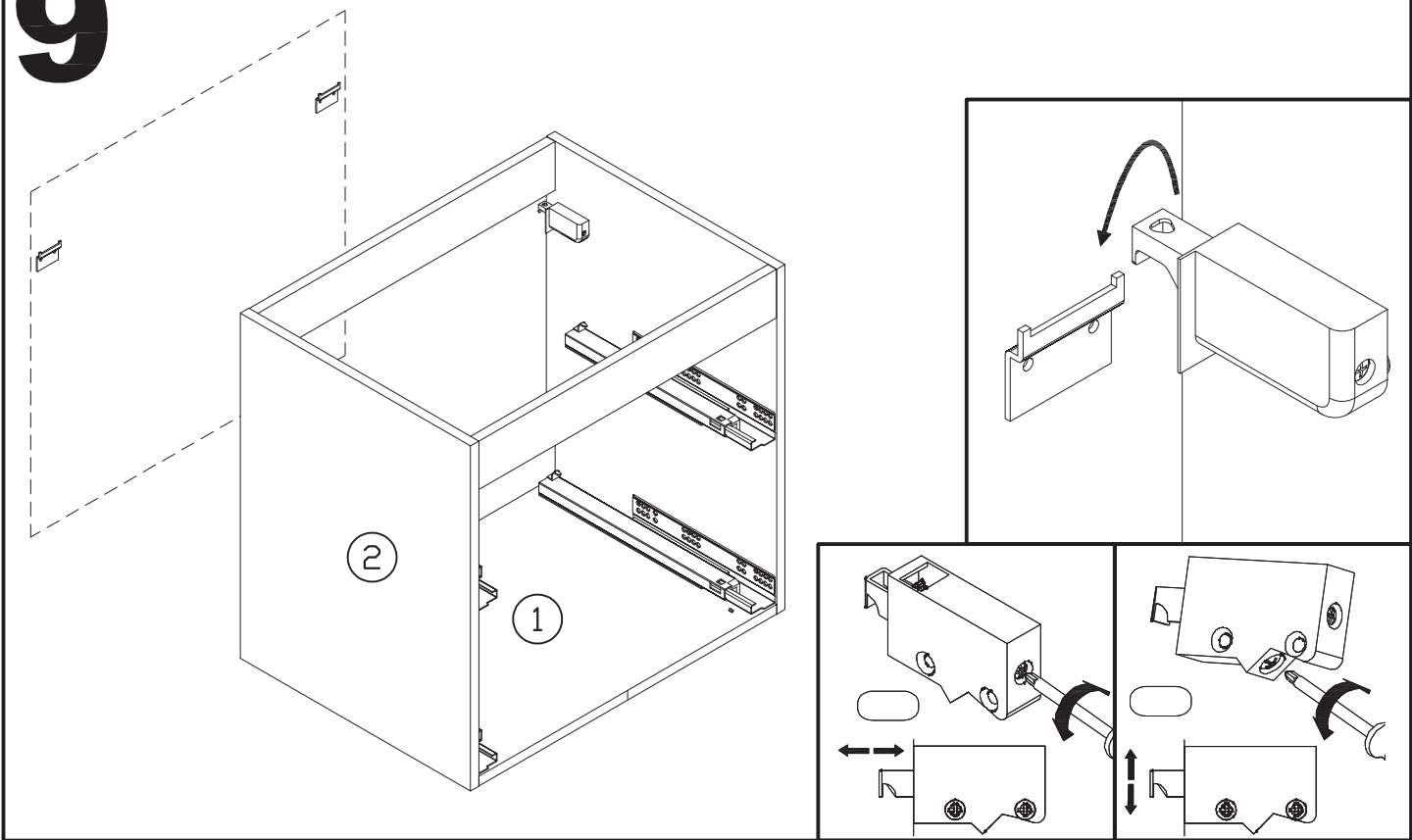

10

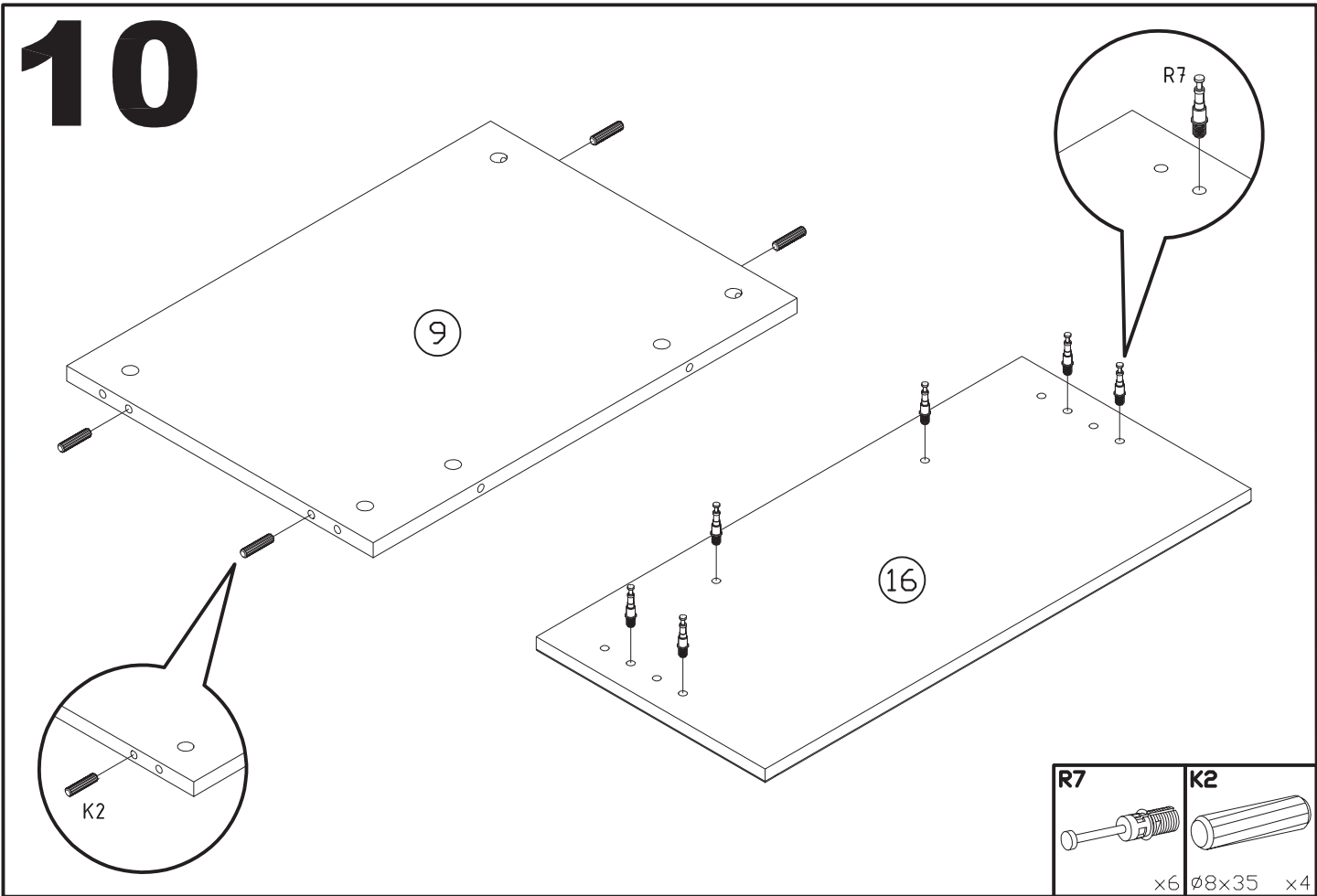

HAVANA WHITE 82-60

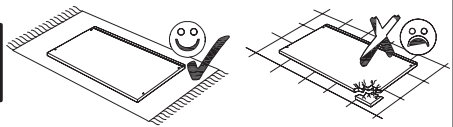

11

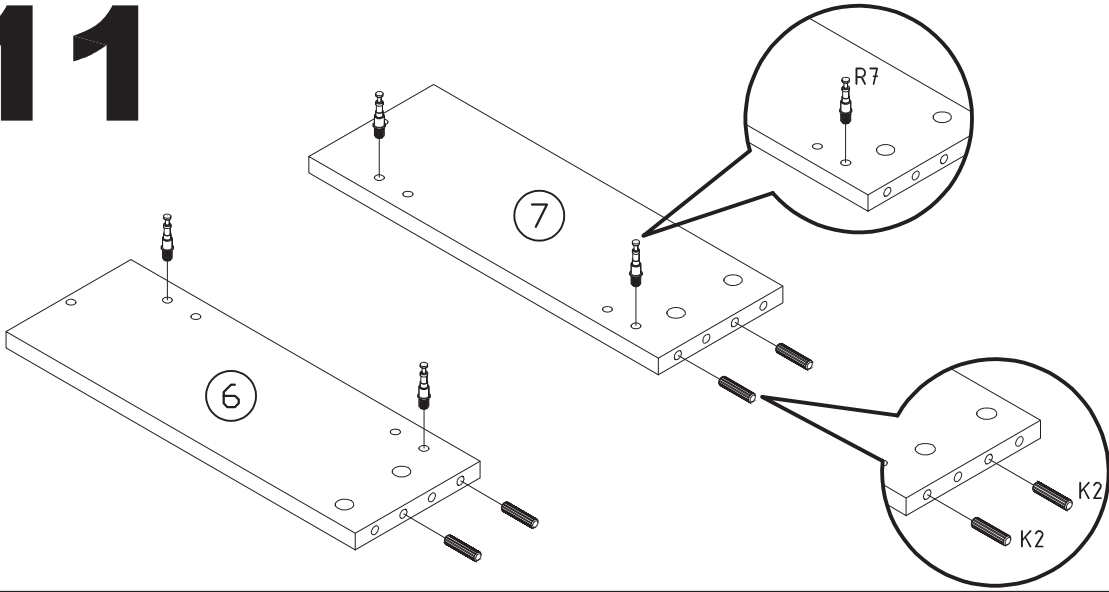

R7		x4
K2		x4
		∅8x35

12

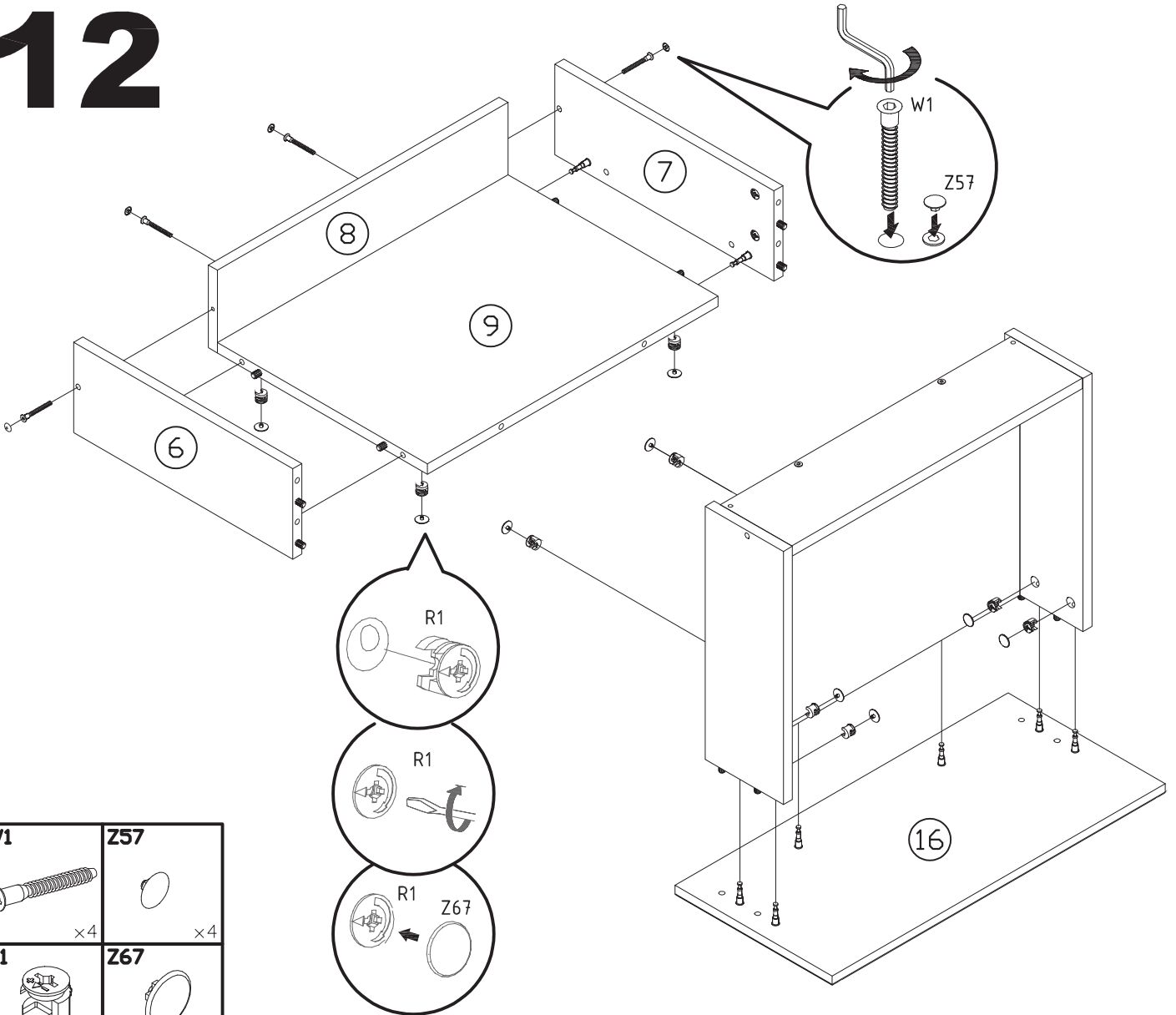

W1		x4	Z57		x4
R1		∅15x12,5 x10	Z67		∅18 x10

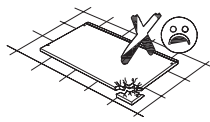
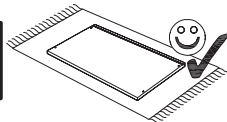

13

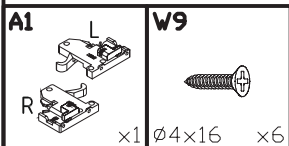
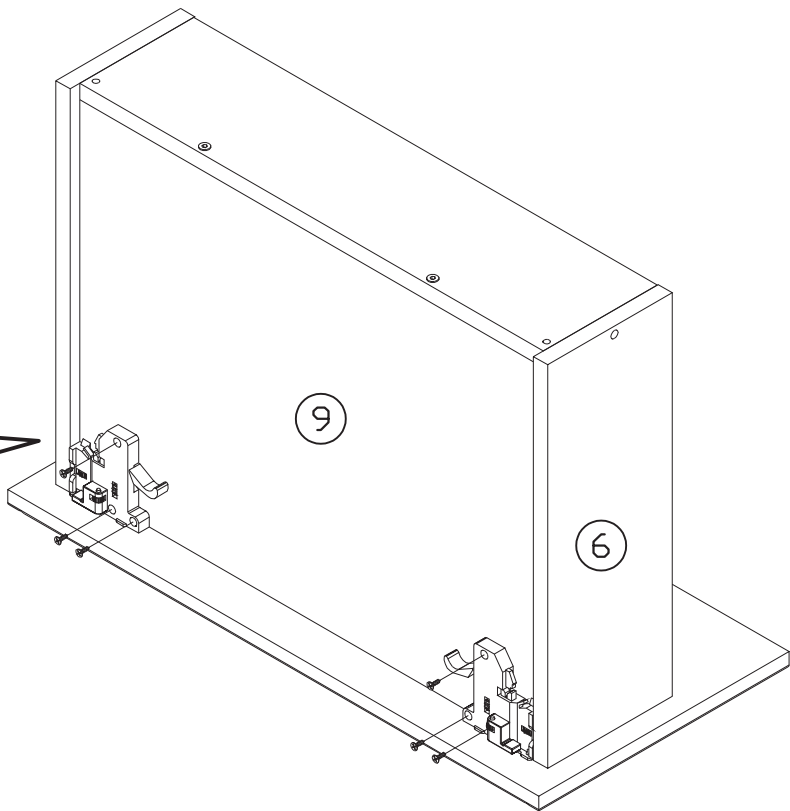
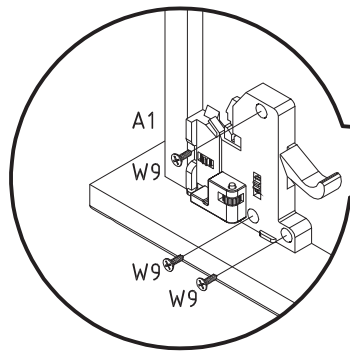

14

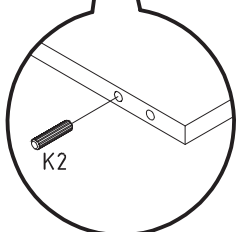
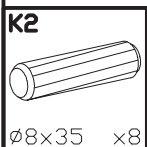
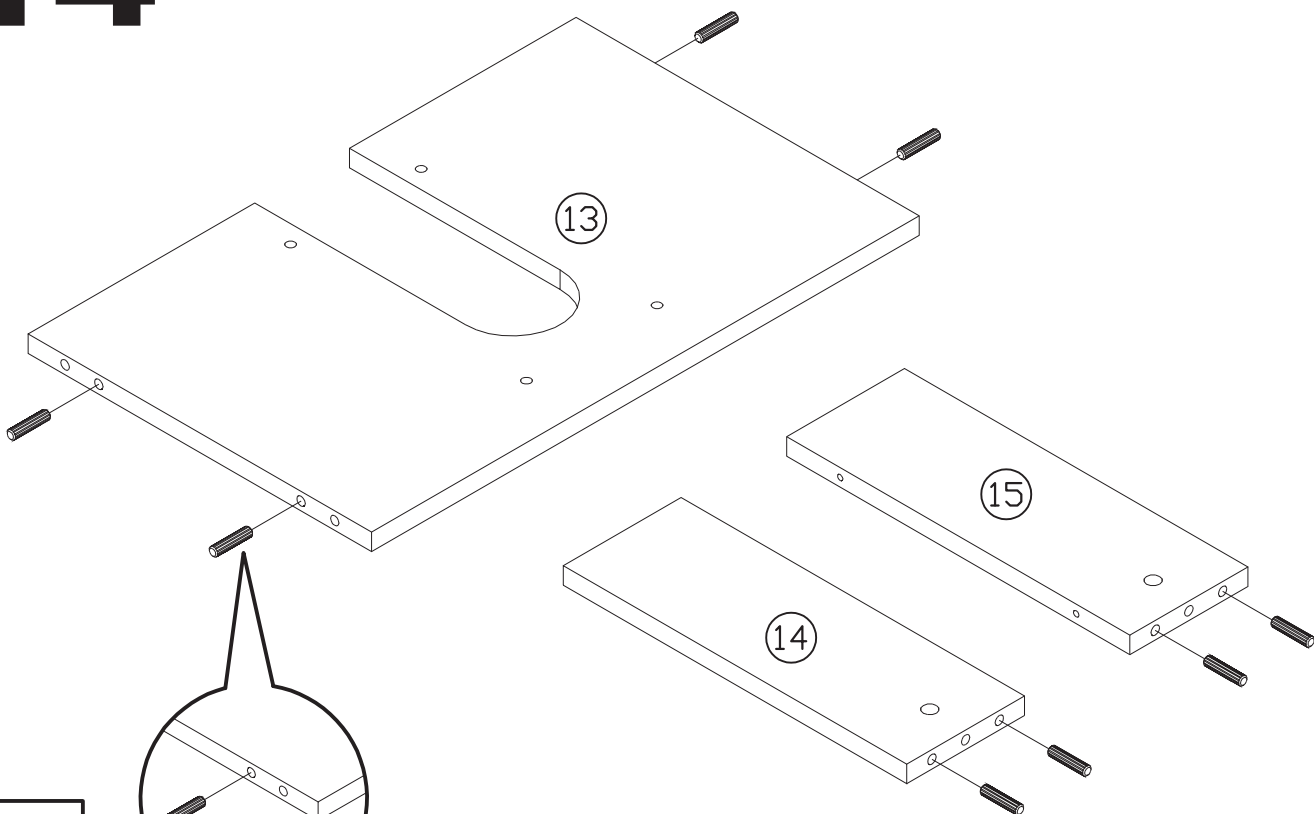

HAVANA WHITE 82-60

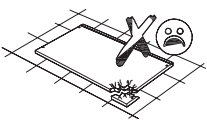
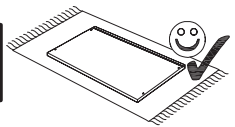

15

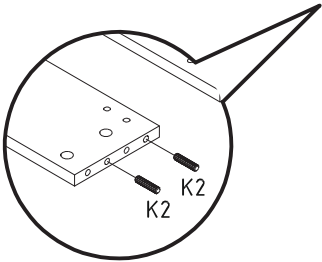
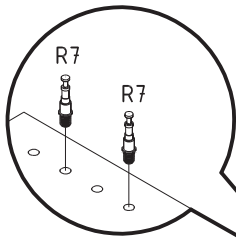
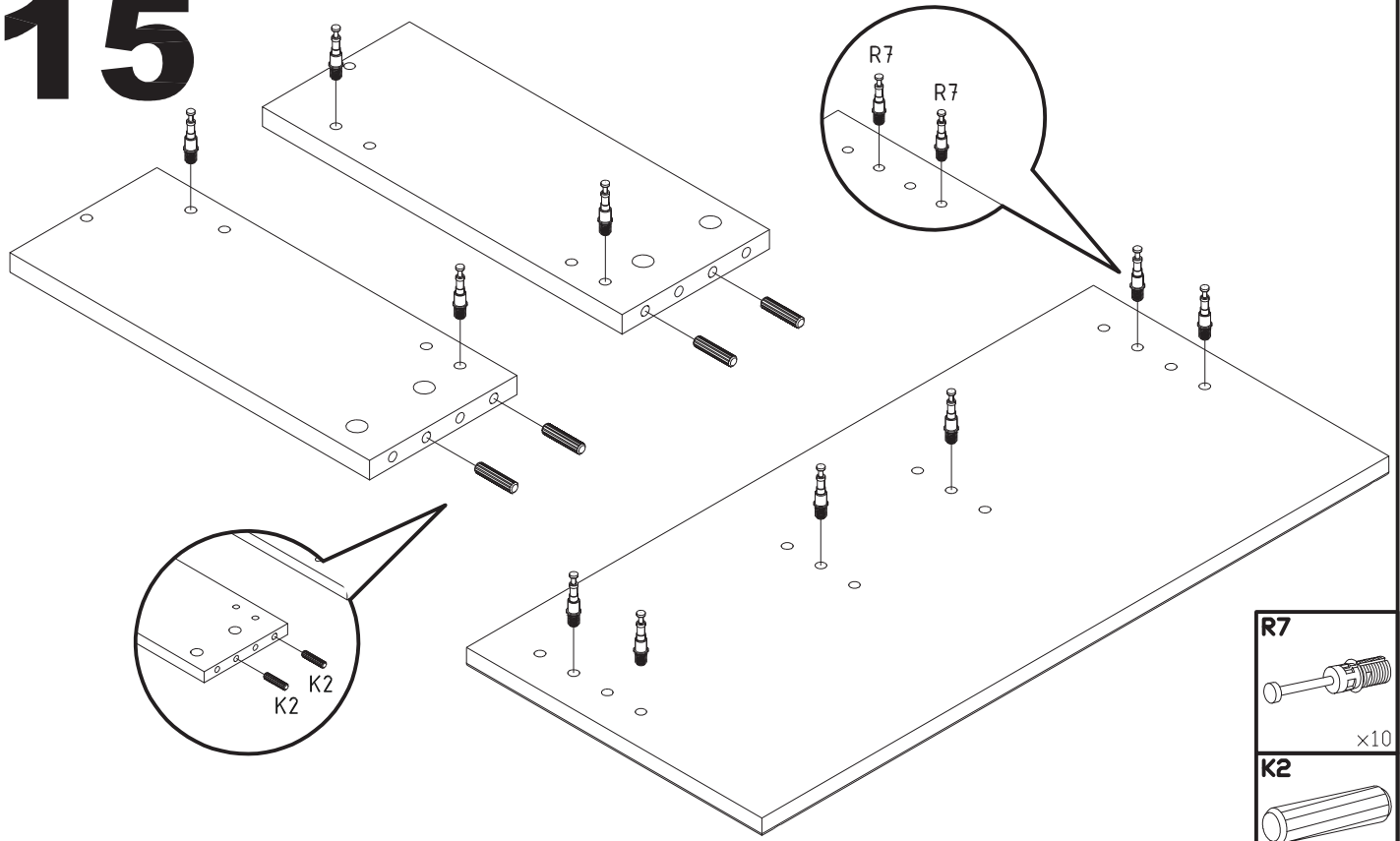

R7		x10
K2		ø8x35 x4

16

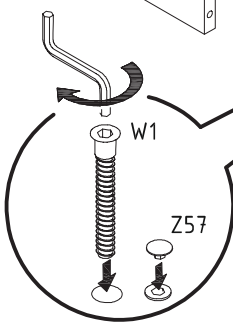
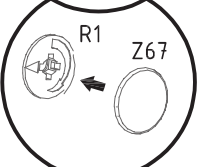
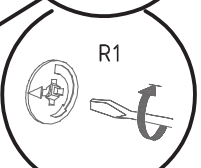
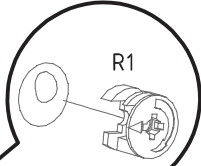
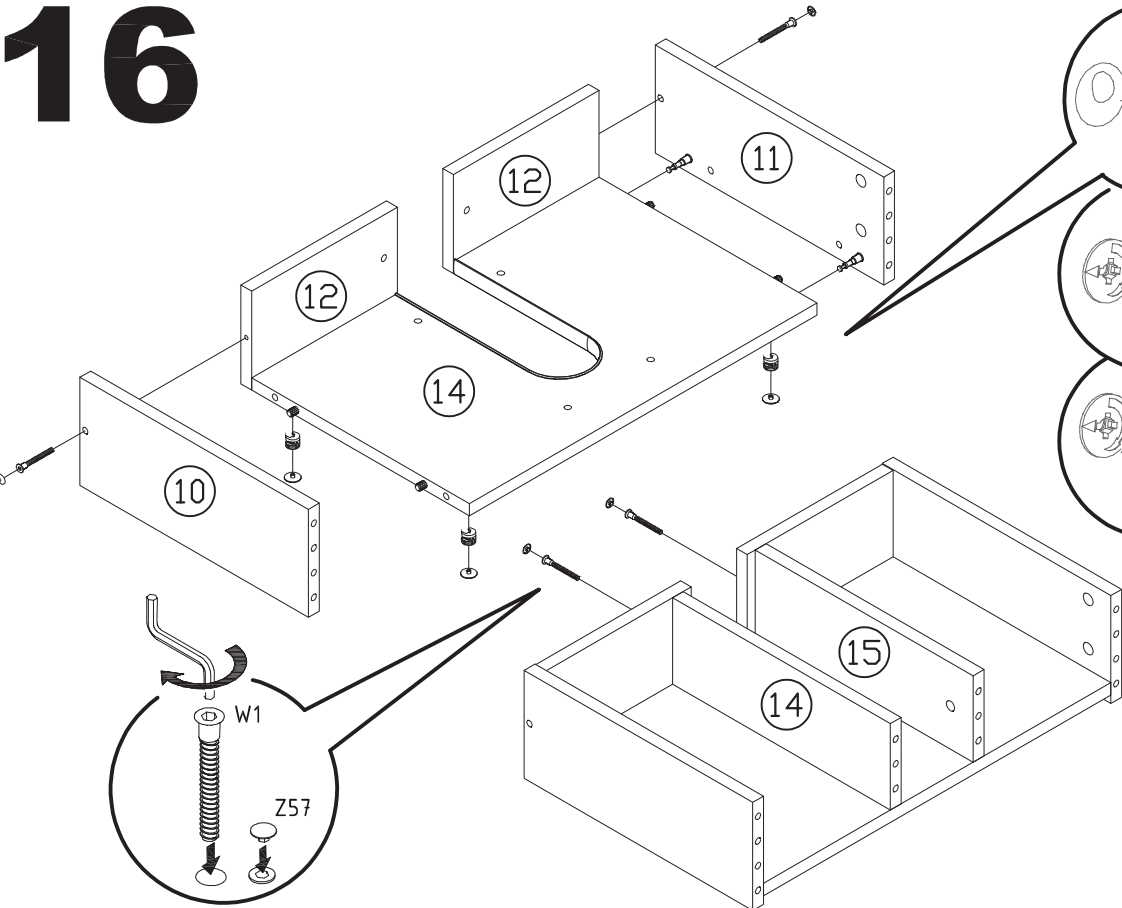

Z57		x4
W1		x4
R1		ø15x12,5 x4
Z67		ø18 x4

HAVANA WHITE 82-60

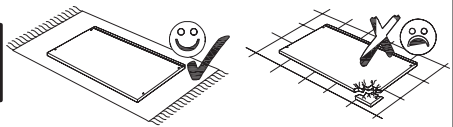

17

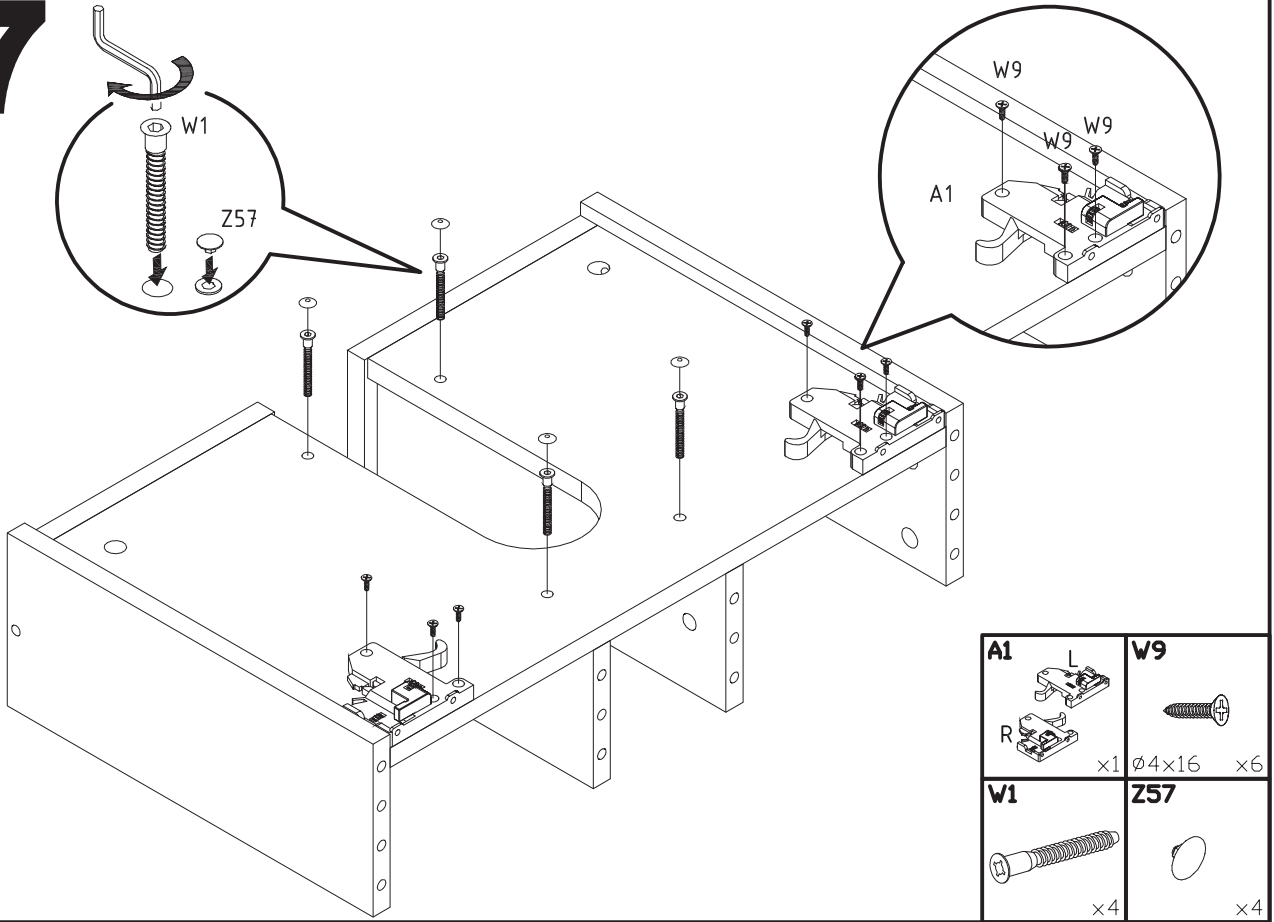

A1 L R	W9 x1 $\varnothing 4 \times 16$ x6
W1 x4	Z57 x4

18

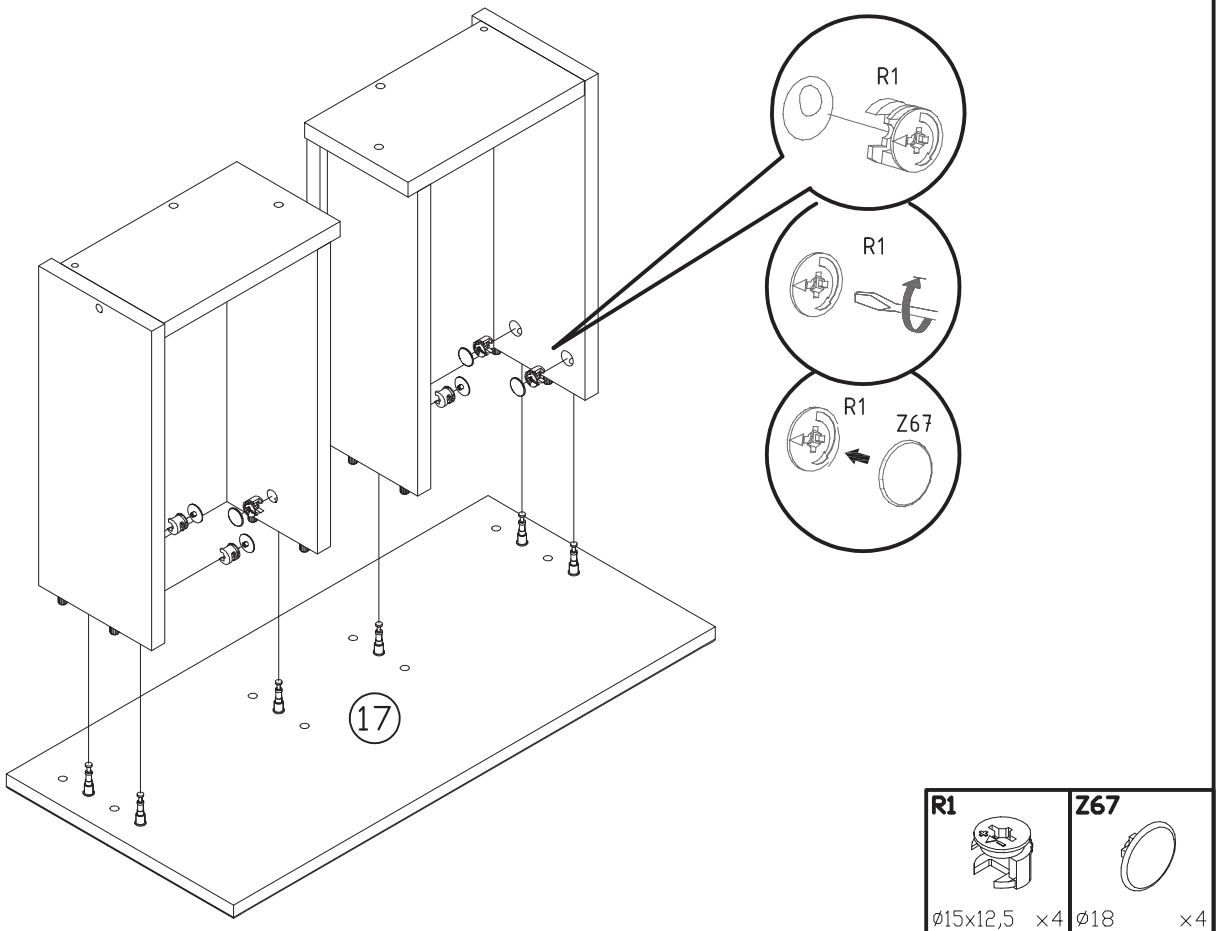

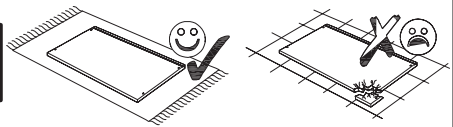

R1 $\varnothing 15 \times 12,5$ x4	Z67 $\varnothing 18$ x4
--	---------------------------------------

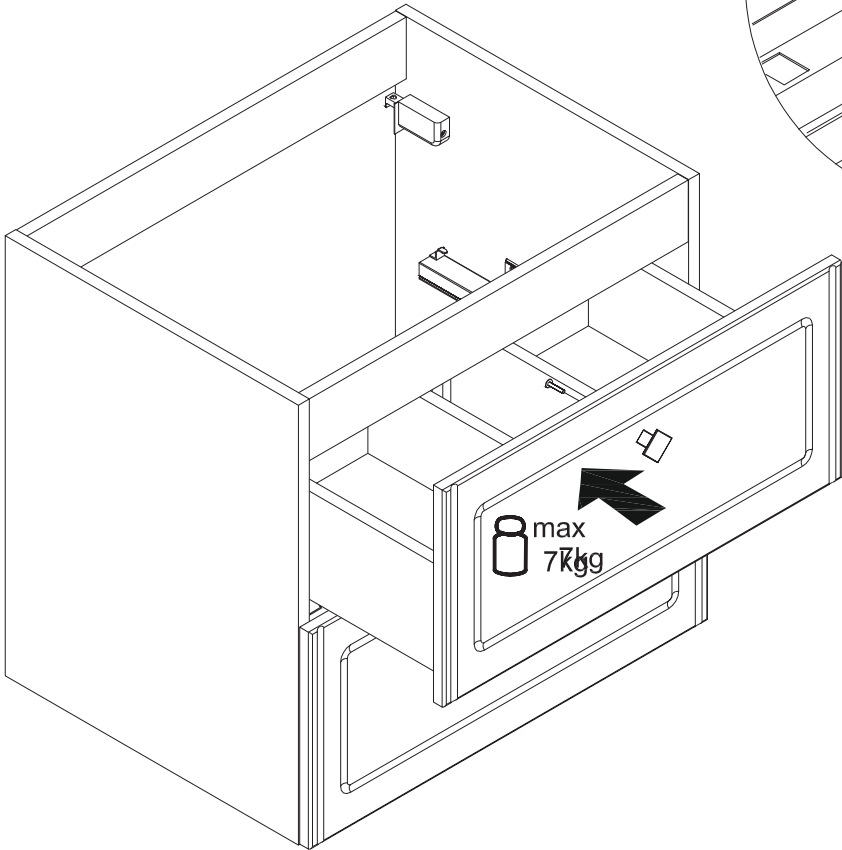
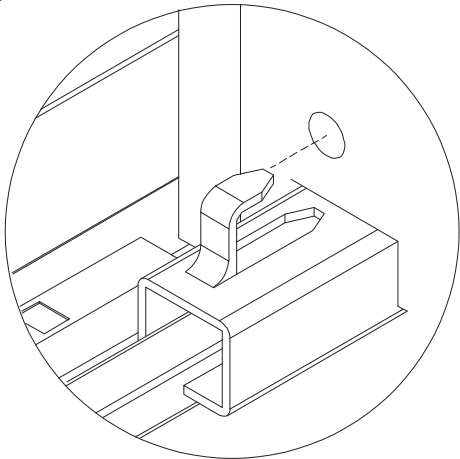
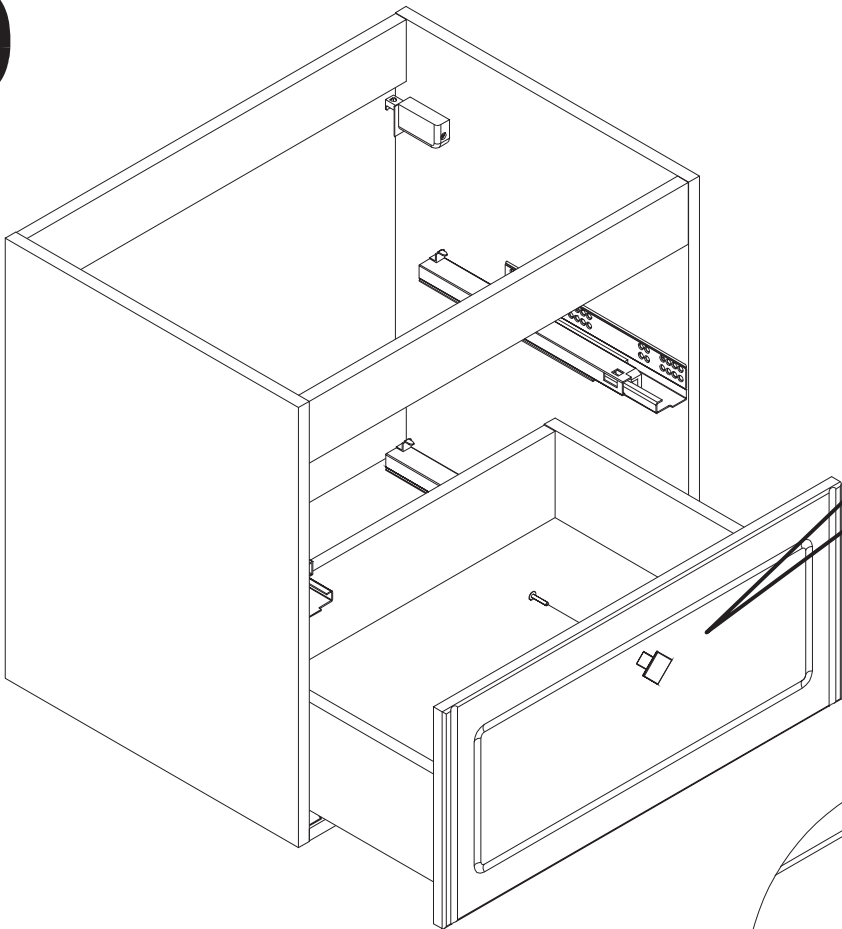

19



U58 	W30 
x2 $\varnothing 4 \times 23$ x2	

HAVANA WHITE 82-60

